

BRAND-FIRST

32309 Milton Avenue
Madison Heights, MI 48071

1-888-583-5353

Fax: 248-588-0051



MANUAL BRANDING MACHINE

Thank you for purchasing your BRAND-FIRST manual branding tool. The following instructions will lead you through the set-up and procedures required to allow you to get the best possible brands from your new branding tool.

Unpacking and set-up of your new branding machine.

Step One: The branding machine is shipped pre-assembled (with the exception of the Handle described in Step Two). Find an area on your work bench that will offer you the most flexibility for positioning your work under the branding tool head. Secure the column of the branding machine to your work bench (Photo 1). The branding head is positioned by sliding the Mounting Arm up or down the column and secured by tightening the two (2) Collar Tightening Knobs (Photo 2). Always tighten rear collar tightening knob first.

Step Two: Attach the Handle to the Clevis Rod end on the Mounting Arm and the Actuating Handle Plate using the Clevis Pins, washers, and retaining rings provided. (Photo 3)

Step Three: Before plugging the unit into your standard 115/120 volt electrical outlet, set the temperature regulator to the "OFF" position.

Preparing your machine to brand your work:

Step One: Your branding machine provides a 2" travel stroke of the branding head (Photo 4). Set the Mounting Arm on the column to allow for approximately 1/8" compression of the disc springs when the branding head presses against the piece to be marked (Photo 5)

Step Two: Turn the temperature regulator to “MAX” and allow 20 minutes for the branding head to heat. Time varies depending on tool wattage, branding head size, ambient temperature, and material being branded.

Step Three: Test brand scrap pieces to arrive at the proper dwell time and temperature regulator setting. With the right temperature setting, you should be able to produce a clean looking, even brand with a 1 second dwell time.

Branding Head Adjustments

If the resultant brand is not uniform, an adjustment to the angle of the head may be required. Use the dual-plate feature to make corrections by “raising” that portion of the head where the darkest branded area occurs.

Step One: Loosen retaining nut(s) (turn counter-clockwise) directly above the section of the branding head that burned darkest (deepest).

Step Two: Turn Bolt Head clockwise (to right) to raise the bottom plate (thus branding head) –or– counter-clockwise (to left) to lower the bottom plate (thus branding head) if necessary.

Step Three: Make small adjustments, then re-brand after each adjustment to check the change in branding result.

Step Four: After the final adjustment, lock into position by turning all retaining nuts clockwise (to right).

Photos 6 & 7 demonstrate how to align the face to the object being branded for a uniform brand.

USE EXTREME CAUTION WHEN USING THIS BRANDING MACHINE. KEEP SMALL CHILDREN AND ANIMALS AWAY. BRANDING HEAD AND ADJACENT PARTS GET EXTREMELY HOT AND MAY CAUSE SERIOUS BURNS. REMEMBER TO ALWAYS WEAR SAFETY GLASSES.

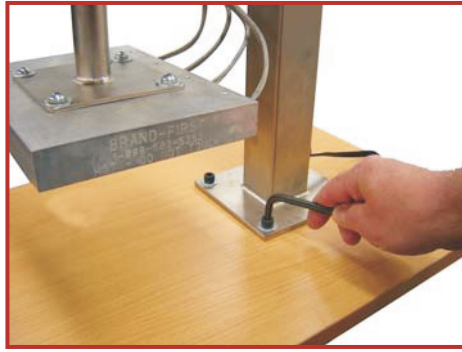

Photo 1



Photo 2

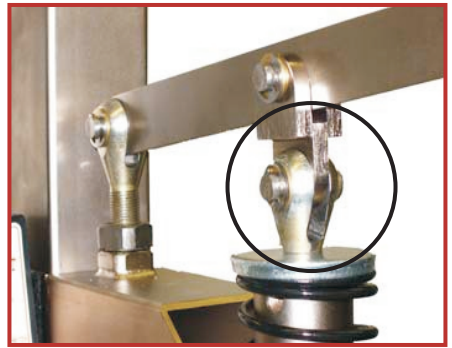

Photo 3

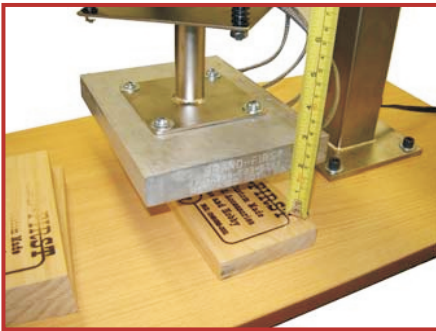
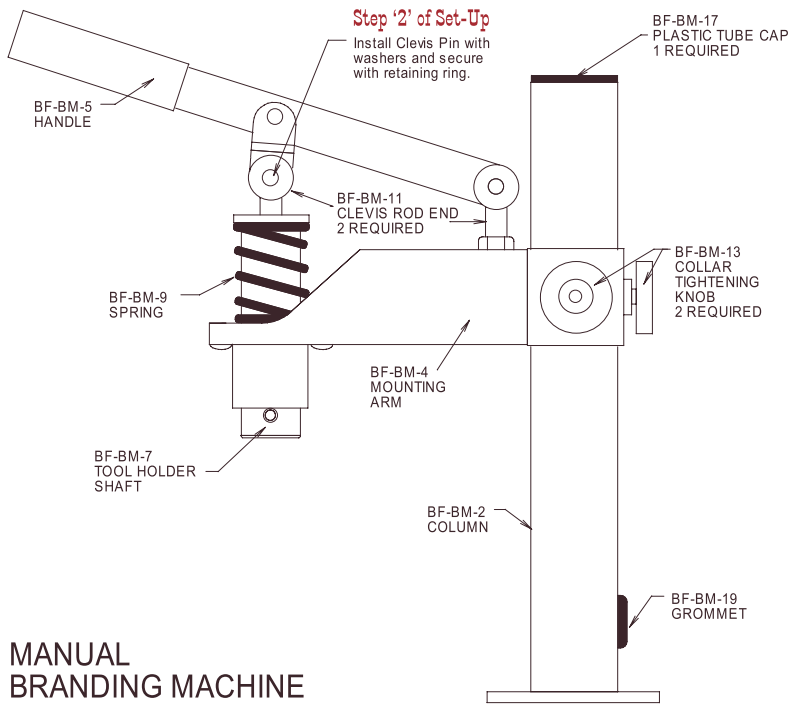

Photo 4



Photo 5



MANUAL BRANDING MACHINE



Photo 6



Photo 7

Photos 6 & 7 demonstrate how to make adjustments necessary to align the face to the iron to the object being branded. Always tighten the bolt directly above the darkest portion of the branded impression.

Photo 8

Once set, uniform and repetitive branding is simple



BRAND-FIRST sales and support staff are available Monday thru Friday 8:00 AM to 4:30 PM to answer any questions. Call 1-888-583-5353